

DATA SHEET

FIBERGLASS ROAD Ø 9 MM

incl. wheeled steel cage, double run-out system, metercounter

Item no.: 10081 | 10082 | 10083 | 10084 | 10085 | 10086 | 10110



VIDEO



Fiberglass rod
Ø 7,5 mm, 9 mm
and 11 mm

[Click here
Video](#)



[Click here
Productinformation](#)

BEGINNING: 

Shackle, stainless steel with RUNPOTEC RTG Ø 12 mm thread - screwed to strand

ENDING: 

Ending joint, stainless steel with RUNPOTEC RTG Ø 12 mm thread

Detailed images:



automatic run-out brake

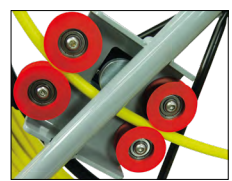

Quick run with mounted rollers

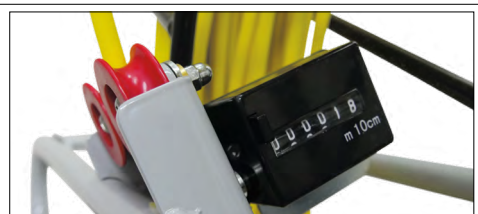

Metercounter

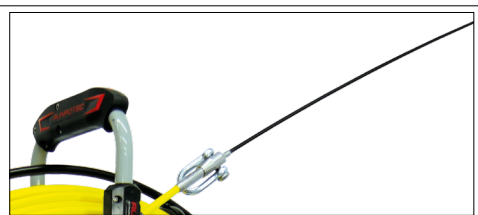



Adaptable leading heads

DATA							
ITEM NO.	10081	10082	10083	10084	10085	10086	10110
LENGTH	40 m	50 m	60 m	80 m	100 m	120 m	150 m
WEIGHT	10,7 kg	11,6 kg	12,6 kg	14,5 kg	18,1 kg	19,9 kg	20,5 kg
MATERIAL	Fiberglass core with PP sheath						
PIPE Ø	for tube diameter 60 - 200 mm						
Total breaking load	460 kg						

ADVANTAGES

- ✓ incl. steel reel and metre counter
- ✓ **Double run-out system**
(automatic run-out brake and fast run-out)
- ✓ **Additional parking brake**
- ✓ **Glass fibre rod total breaking load up to 4500 kg**
- ✓ **Total towing capacity 460 kg**
- ✓ **Bending radius 620 mm**

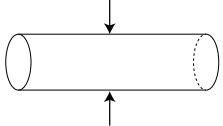
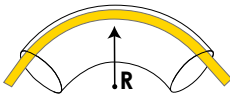
Rec. tube diameter, bending radius and total breaking load

Ø				
9 mm	60 - 200 mm	620 mm	4500 kg	460 kg

DESCRIPTION

Cable puller glass fibre rod Ø 9 mm - RUNPOTEC RTG Ø 12 mm thread with robust steel reel (galvanised/powder coated) Ø 730 mm incl. new double run-out system (automatic run-out brake and fast run-out), additional parking brake. The shackle also has a transition thread to RTG Ø 6 mm to adapt various guide rods (RUNPOST-ICKS), guide probes, cable pulling sleeves, multifunction camera RC 2 and the like. Fiberglass rod total breaking load 3400 kg, total breaking load 400 kg.

Optimal field of application: for pipe diameters 50 mm - 120 mm.

Application video: a short, very informative application video can be viewed by scanning the QR code or on www.runpotec.com.

Scope of delivery: 1 piece of glass fibre rod Ø 9 mm with steel reel and new double run-out system, end sleeves on both sides (start/end), 1 x metre counter, 1 x shackle

INFORMATION

Compatible with:

RUNPOCAM RC2

Length: 10 m | 30 m | 50 m
Item no. 10139 | 10140 | 10141



[Click here
Productinformation](#)